

BC 03



BETEC CAD.

Fire Dampers



Selected Products of the company have been Classified / Listed / Tested by various international testing authorities.





BETEC CAD.

BREAKS

FIRE & SMOKE

“BUILDING CONDITIONED AIR FOR LIFE SAFETY”

BETEC CAD. manufactures life safety dampers, based on **SMACNA, NFPA & UL** technological data, in the interest of improving the safety for public benefit.

Today, as per **BOCA & IBC** Standards, building safety is a demandable choice by the public in case of fire accidents. **BETEC CAD's** Fire dampers are manufactured in accordance with **UL 555** standards to prevent the spread of Smoke or Fire breakouts.

LIFE SAFETY DAMPERS – FD-GB-20/21/30/31 FOR BUILDING & COMMERCIAL VENTILATION



Fire Damper
Fire Rating : 1-1/2 Hrs /3 Hrs.

For more details about **BETEC CAD's** UL Classified Products.

Please Contact us :
BETEC CAD. IND. (FZC)
Saif Zone Sharjah - UAE
Po Box No : 8805
Tel : + 971 6 5575252; Fax : + 971 6 5575151/61
E- mail : info@beteccad.com ; Web : www.beteccad.com



Selected Products of the company have been Classified / Listed / Tested by various international testing authorities.



UL-555 Classified Fire Damper

Fire Damper Application

Fire Dampers are required by the International Uniform Building Code to maintain the required fire resistance rating of walls, partitions, and floors when they are penetrated by air ducts or other ventilation openings.

A duct or ventilation openings in any of the fire rated partitions would permit a fire to spread from the compartment of origin to adjoining compartments or space. Fire Dampers are installed in these ducts or ventilation openings. They close automatically upon detection of heat by a Heat / Fusible Link, blocking the openings and preventing the spread of fire into the adjoining compartment.

Fire dampers shall be constructed to restrict the passage of flame when in the closed position. Combination fire and smoke dampers and fire dampers for dynamic systems shall be constructed to close under the rated airflow and heat conditions.

NFPA Requires UL (Underwriters Laboratories) Classified Fire dampers as follows

1½ hour classified fire dampers are appropriate for use in walls, partitions and floors having fire resistance ratings of less than 3 hours. (NFPA standard 90A). 3 hour classified fire dampers are appropriate for use in walls, partitions and floors having fire resistance ratings of 3 hours or more. (NFPA standard 90A).

Specifications

Fire / Smoke dampers meeting or exceeding the following specifications shall be furnished and installed at locations shown on plans or as described in schedules. Dampers shall meet the requirements of NFPA 90A and SMACNA rated dampers for use as Fire barriers for 1½ hr. / 3 hrs fire rating in accordance with the latest version of UL 555.

Fire dampers used for the protection of openings in walls, partitions, or floors with fire resistance ratings of less than 3 hours shall have a 1 ½ hour fire protection rating.

Fire dampers used for the protection of openings in walls, partitions, or floors having a fire resistance rating of 3 hours or more shall have a 3 hour fire protection rating.



UL-Classified Fire Damper-555 Static / Dynamic Galvanized Steel (GI) Construction

Fire Rating : 1½ Hr. / 3 Hr.

FD-B Series is a high performance UL 555 Classified Fire Damper with 1½ hr. / 3hr. fire rating, to ensure lowest resistance to airflow in HVAC systems with operational velocities of upto 2000 fpm (10.2 m/sec.) and 4" w.g. (1000Pa) pressure. The dampers can be installed Vertically or Horizontally (with blades running horizontally) and is rated for airflow in either direction.

BETEC CAD's UL Classified Fire Dampers are tested for the following high performance tests as per UL555 standards :

Fire Endurance Test and Hose Stream Test

Operational Reliability Cycling Test

Dynamic Closure Test

Salt Spray Exposure Test

UL-555 Fire Ratings

Fire Rating : 1½ hrs. Or 3 hrs.
 Max. Velocity : up to 2000 fpm (10.2 m/s)
 Pressure : 4 inches water gauge (1000 pa)

Velocity and Pressure Ratings are for Dynamic Systems.

Selected Products of the company have been Classified / Listed / Tested by various international testing authorities.



UL-555 Classified Fire Damper

Type : Fire Damper
 Model : FD-GB-20-AS/BS/AF/BF/R
 Fire Rating : 20 Series: 1½ hour
 Construction : Galvanized Steel (GI)

B-20 Series

UL- 555 Test Ratings

Fire Rating : 1½ hrs.

Standard Construction

Frame

18 gauge (1.2 mm) thick galvanized steel.

Blades

Curtain type blade made of 22 gauge (0.8 mm) thick galvanized steel.

Fusible Link

165°F.

Blade Ramp

16 gauge (1.5 mm) thick galvanized steel angle.

Spring

0.3 mm thick by 19 mm wide, stainless steel constant force spring.

Mounting

Vertical / Horizontal

Sleeve

Minimum 0.7 mm, single section is field or factory installed.
 Multiple section is factory installed.
 Sleeve thickness as per NFPA table 3-4.6.3.

Optional Fittings

Retaining Angles

1½" x 1½" x 16 gauge (40 x 40 x 1.5) mm.

Limit Switches

For BMS open / close indication.

Transitions (R)

Neck adapter for round duct connections.

Standard Sizes Any Combination (W x H)			
W	H	h	Module
4"	4"	1"	Single
10"	10"	1"	Single
12"	12"	1"	Single
16"	16"	1.5"	Single
20"	20"	2"	Single
24"	24"	2.5"	Single
30"	30"	3"	Single
36"	36"	3.5"	Single
39 ½ "	39½ "	3.5"	Single
72"	72"	3.5"	Multiple

Optional Construction (UL Certification N/A)

Frame : Stainless Steel 18 gauge (304/316L)

Blade : Stainless Steel 22 gauge (304/316L)

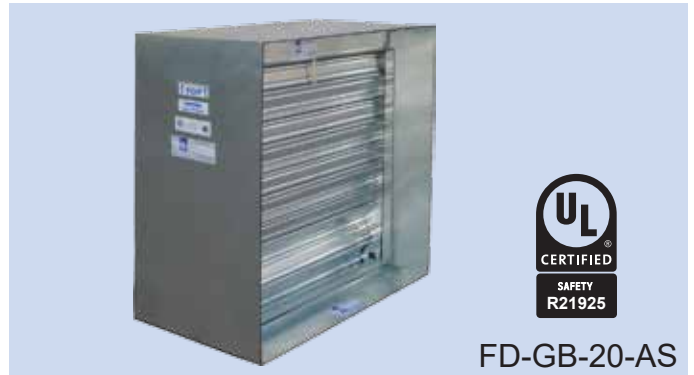

Model : FD-GB-20-AS/BS/AF/BF/R UL 555 Damper meets the required standards of SMACNA, NFPA, IBC, BOCA, ICBO, UL.

Sleeve Mounting Details

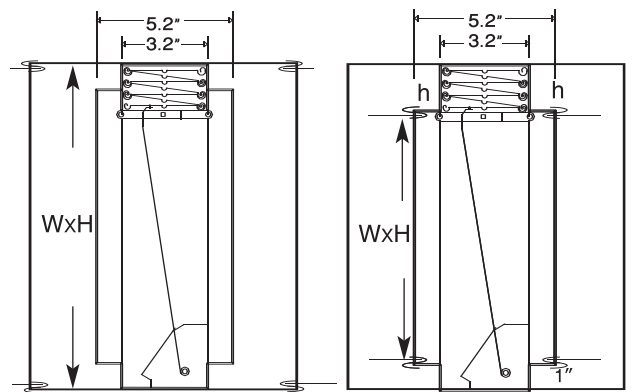

Blades in Air stream
FD-GB-20-AS

Blades above Air stream
FD-GB-20-BS

Model of Fire Damper FD-GB/D-20 A/B/AS/BS/AF/BF/R	
A	Blades in air stream
B	Blades above air stream
AS	Blades in air stream with sleeve
BS	Blades above air stream with sleeve
AF	Blades in air stream with mounting frame
BF	Blades above air stream with mounting frame
R	Round Spigot

Size Limitation		
Module	Size : Width x Height	Position
Single	Max X Max 36" x 36"	V/H
Single	Max X Max 39½" x 39½"	V
Multiple	Max X Max 72" x 72"	V



UL Classified (see mark on product)
 UL Classified to American/Intl safety standards
 UL Standard 555 (Listing # R21925)

Selected Products of the company have been Classified / Listed / Tested by various international testing authorities.



UL-555 Classified Fire Damper

Type : Fire Damper
Model : FD-GBD-20-AS/BS/AF/BF/R
Fire Rating : 20 Series: 1½ hour
Construction : Galvanized Steel (GI)

B-20 Series

UL- 555 Test Ratings

Fire Rating : 1½ hrs.
 Max Velocity : 2000 fpm (for Dynamic Systems)

Standard Construction

Frame

18 gauge (1.2 mm) thick galvanized steel.

Blades

Curtain type blade made of 22 gauge (0.8 mm) thick galvanized steel.

Fusible Link

165°F.

Blade Ramp

16 gauge (1.5 mm) thick galvanized steel angle.

Spring

0.33 mm thick by 19 mm wide, stainless steel constant force spring.

Mounting

Vertical

Sleeve

Minimum 0.7 mm, single section is field or factory installed. Multiple section is factory installed. Sleeve thickness as per NFPA table 3-4.6.3.

Optional Fittings

Retaining Angles

1½" x 1½" x 16 gauge (40 x 40 x 1.5) mm.

Limit Switches

For BMS open / close indication.

Transitions (R)

Neck adapter for round duct connections.

Standard Sizes Any Combination (W x H)			
W	H	h	Module
4"	4"	1"	Single
10"	10"	1"	Single
12"	12"	1"	Single
16"	16"	1.5"	Single
20"	20"	2"	Single
24"	24"	2.5"	Single
30"	30"	3"	Single
36"	36"	3.5"	Single

Optional Construction (UL Certification N/A)

Frame : Stainless Steel 18 gauge (304/316L)

Blade : Stainless Steel 22 gauge (304/316L)



Model : FD-GBD-20-AS/BS/AF/BF/R UL 555 Damper meets the required standards of SMACNA, NFPA, IBC, BOCA, ICBO, UL.

Sleeve Mounting Details

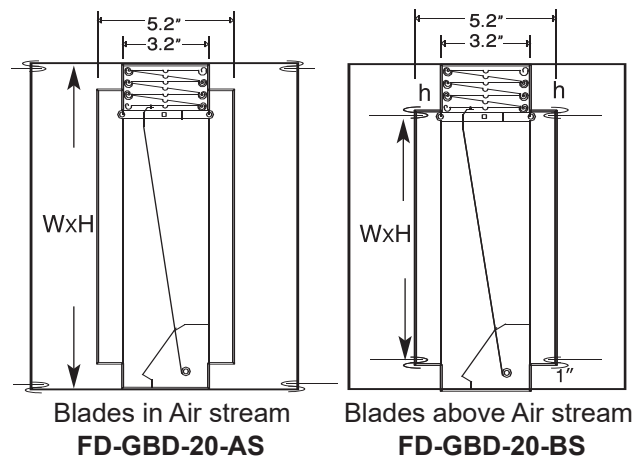

Model of Fire Damper FD-GB/D-20 A/B/AS/BS/AF/BF/R	
A	Blades in air stream
B	Blades above air stream
AS	Blades in air stream with sleeve
BS	Blades above air stream with sleeve
AF	Blades in air stream with mounting frame
BF	Blades above air stream with mounting frame
R	Round Spigot

Size Limitation		
Module	Size : Width x Height	Position
Single	Max X Max 36" x 36"	V



UL Classified (see mark on product)
 UL Classified to American/Intl safety standards
 UL Standard 555 (Listing # R21925)

Selected Products of the company have been Classified / Listed / Tested by various international testing authorities.



UL-555 Classified Fire Damper

B-20 Series

Type : Fire Damper
 Model : FD-GB/SB/GSB/SGB-22-A/B/AS/BS/R
 Fire Rating : 20 Series: 1½ hour
 Construction : Galvanized Steel (GI)
 Stainless Steel (SS)

UL- 555 Test Ratings

Fire Rating : 1½ hrs.

Standard Construction

Frame

20 gauge (0.9 mm) thick galvanized steel / stainless steel

Blades

Curtain type blade made of 22 gauge (0.8 mm) thick galvanized steel / stainless steel.

Fusible Link

165°F.

Blade Ramp

16 gauge (1.5 mm) thick galvanized steel / stainless steel angle.

Spring

0.3 mm thick by 19 mm wide, stainless steel constant force spring.

Mounting

Vertical

Optional Fittings

Sleeve

Minimum 0.7 mm, single section is field or factory installed. Multiple section is factory installed.

Sleeve thickness as per NFPA table 3-4.6.3.

Retaining Angles

1½" x 1½" x 16 gauge (40 x 40 x 1.5) mm.

Limit Switches

For BMS open / close indication.

Transitions (R)

Neck adapter for round duct connections.

Standard Sizes Any Combination (W x H)			
W	H	h	Module
4"	4"	1"	Single
10"	10"	1.25"	Single
12"	12"	1.3"	Single
16"	16"	1.6"	Single
20"	20"	2"	Single
24"	24"	2.5"	Single
30"	48"	4"	Single
60"	48"	4"	Multiple



FD-SB-22-A

Model :FD-GB/SB/GSB/SGB-22-A/B/AS/BS/R UL 555 Damper meets the required standards of SMACNA, NFPA, IBC, BOCA, ICBO, UL.

Sleeve Mounting Details

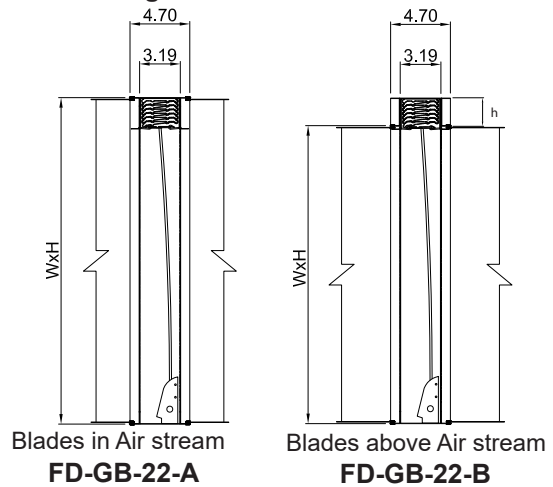

Model of Fire Damper FD-GB/SB/GSB-22-A/B/AS/BS/R	
A	Blades in air stream
B	Blades above air stream
AS	Blades in air stream with sleeve
BS	Blades above air stream with sleeve
R	Round Spigot

Size Limitation		
Module	Size : Width x Height	Position
Single	Max X Max 30" x 48"	V
Multiple	Max X Max 60" x 48"	V

UL Classified (see mark on product)
 UL Classified to American/Intl safety standards
 UL Standard 555 (Listing # R21925)

Selected Products of the company have been Classified / Listed / Tested by various international testing authorities.

UL-555 Classified Fire Damper

Type : Fire Damper
Model : FD-GB-30-AS/BS/R
Fire Rating : 30 Series: 3 hour
Construction : Galvanized Steel (GI)

UL- 555 Test Ratings

Fire Rating : 3 hrs.

Standard Construction

Frame

18 gauge (1.2 mm) thick galvanized steel.

Blades

Curtain type blade made of 22 gauge (0.8 mm) thick galvanized steel.

Fusible Link

165°F.

Blade Ramp

16 gauge (1.5 mm) thick galvanized steel angle.

Spring

0.3 mm thick by 19 mm wide, stainless steel constant force spring.

Mounting

Vertical

Sleeve

Minimum 0.7 mm, single section is field or factory installed.
 Multiple section is factory installed.
 Sleeve thickness as per NFPA table 3-4.6.3.

Optional Fittings

Retaining Angles

1½" x 1½" x 16 gauge (40 x 40 x 1.5) mm.

Limit Switches

For BMS open / close indication.

Transitions (R)

Neck adapter for round duct connections.

Standard Sizes Any Combination (W x H)			
W	H	h	Module
4"	4"	1"	Single
10"	10"	1"	Single
12"	12"	1"	Single
16"	16"	1.5"	Single
20"	20"	2"	Single
24"	24"	2.5"	Single
30"	30"	3"	Single
36"	36"	3.5"	Single
39 ½ "	39½ "	3.5"	Single
72"	72"	3.5"	Multiple

B-30 Series

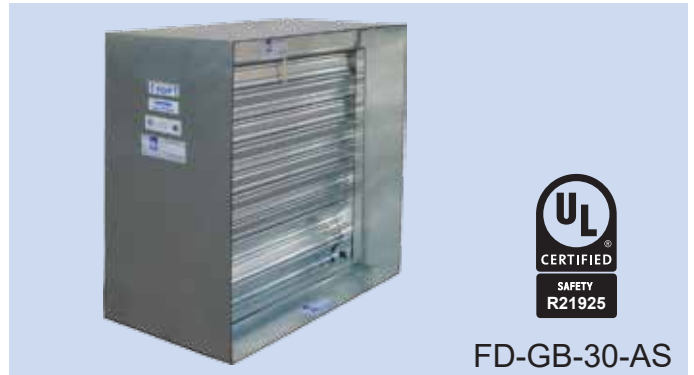

Model : FD-GB-30-AS/BS/R UL 555 Damper meets the required standards of SMACNA, NFPA, IBC, BOCA, ICBO, UL.

Sleeve Mounting Details

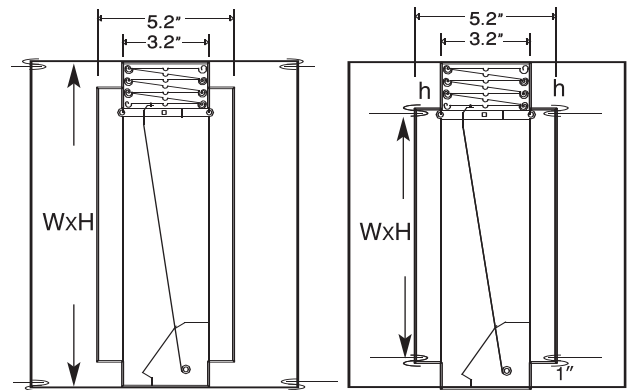

Blades in Air stream
FD-GB-30-AS

Blades above Air stream
FD-GB-30-BS

Model of Fire Damper FD-GB/D-30-A/B/AS/BS/R	
A	Blades in air stream
B	Blades above air stream
AS	Blades in air stream with sleeve
BS	Blades above air stream with sleeve
R	Round Spigot

Size Limitation		
Module	Size : Width x Height	Position
Single	Max X Max 39½" x 39½"	V
Multiple	Max X Max 72" x 72"	V

Optional Construction (UL Certification N/A)

Frame : Stainless Steel 18 gauge (304/316L)

Blade : Stainless Steel 22 gauge (304/316L)

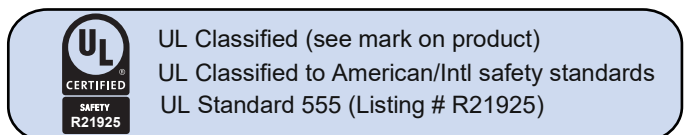

Selected Products of the company have been Classified / Listed / Tested by various international testing authorities.



UL-555 Classified Fire Damper

Type : Fire Damper
Model : FD-GBD-30-AS/BS/R
Fire Rating : 30 Series: 3 hour
Construction : Galvanized Steel (GI)

B-30 Series

UL- 555 Test Ratings

Fire Rating : 3 hrs.
Max Velocity : 2000 fpm (for Dynamic Systems)

Standard Construction

Frame

18 gauge (1.2 mm) thick galvanized steel.

Blades

Curtain type blade made of 22 gauge (0.8 mm) thick galvanized steel.

Fusible Link

165°F.

Blade Ramp

16 gauge (1.5 mm) thick galvanized steel angle.

Spring

0.33 mm thick by 19 mm wide, stainless steel constant force spring.

Mounting

Vertical

Sleeve

Minimum 0.7 mm, single section is field or factory installed.
 Multiple section is factory installed.
 Sleeve thickness as per NFPA table 3-4.6.3.

Optional Fittings

Retaining Angles

1½" x 1½" x 16 gauge (40 x 40 x 1.5) mm.

Limit Switches

For BMS open / close indication.

Transitions (R)

Neck adapter for round duct connections.

Standard Sizes Any Combination (W x H)			
W	H	h	Module
4"	4"	1"	Single
10"	10"	1"	Single
12"	12"	1"	Single
16"	16"	1.5"	Single
20"	20"	2"	Single
24"	24"	2.5"	Single
30"	30"	3"	Single
36"	36"	3.5"	Single



FD-GBD-30-AS

Model : FD-GBD-30-AS/BS/R UL 555 Damper meets the required standards of SMACNA, NFPA, IBC, BOCA, ICBO, UL.

Sleeve Mounting Details

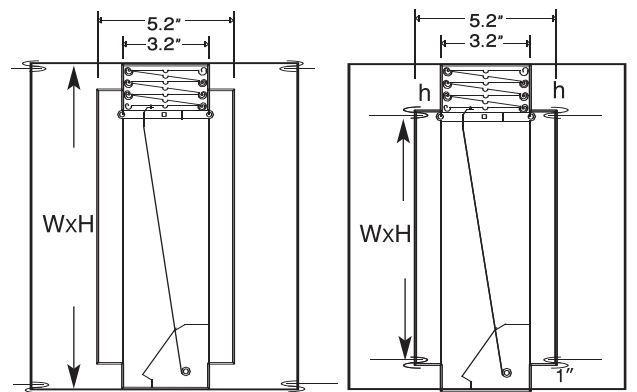

Blades in Air stream
FD-GBD-30-AS

Blades above Air stream
FD-GBD-30-BS

Model of Fire Damper FD-GB/D-30-A/B/AS/BS/R	
A	Blades in air stream
B	Blades above air stream
AS	Blades in air stream with sleeve
BS	Blades above air stream with sleeve
R	Round Spigot

Size Limitation		
Module	Size : Width x Height	Position
Single	Max X Max 36" x 36"	V

Optional Construction (UL Certification N/A)

Frame : Stainless Steel 18 gauge (304/316L)

Blade : Stainless Steel 22 gauge (304/316L)



UL Classified (see mark on product)
 UL Classified to American/Intl safety standards
 UL Standard 555 (Listing # R21925)

Selected Products of the company have been Classified / Listed / Tested by various international testing authorities.

UL-555 Classified Fire Damper

Type : Fire Damper
Model : FD-GB-21/31-A/B/AS/BS/R
Fire Rating : 21 Series: 1½ hour; 31 Series: 3 hour
Construction : Galvanized Steel (GI)

UL- 555 Test Ratings

Fire Rating : 1½ hrs / 3 hrs

Standard Construction

Frame

18 gauge (1.2 mm) thick galvanized steel.

Blades

Curtain type blade made of 22 gauge (0.8 mm) thick galvanized steel.

Fusible Link

165°F (74°C).

Blade Ramp

16 gauge (1.5 mm) thick galvanized steel angle.

Spring

0.3 mm thick by 19 mm wide constant force spring formed from stainless steel.

Mounting

Vertical / Horizontal

Sleeve

Minimum 0.7 mm, single section is field or factory installed. Multiple section is factory installed.

Sleeve thickness as per NFPA table 3-4.6.3.

Optional Fittings

Retaining Angles

1½" x 1½" x 16 gauge (40x40x1.5 mm).

Limit Switches

For BMS open / close indication.

Transitions (R)

Neck adpoter for round duct connections.

Standard Sizes Any Combination (W x H)			
W	H	h	Module
4"	4"	1"	Single
10"	10"	1"	Single
12"	12"	1"	Single
16"	16"	1.5"	Single
20"	20"	2"	Single
24"	24"	2.5"	Single
30"	30"	3"	Single
36"	36"	3.5"	Single
39 ½ "	39 ½ "	3.5"	Single
72"	72"	3.5"	Multiple
144"	96"	3.5"	Multiple

B-21/31 Series



Model : FD-GB-21/31-A/B/AS/BS/R UL 555 Damper meets the required standards of SMACNA, NFPA, IBC, BOCA, ICBO, UL.

Sleeve Mounting Details

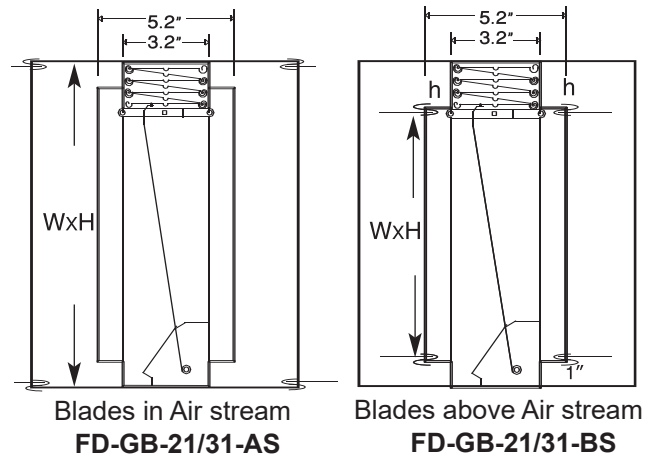

Model of Fire Damper FD-GB-21/31-A/B/AS/BS/R	
A	Blades in air stream
B	Blades above air stream
AS	Blades in air stream with sleeve
BS	Blades above air stream with sleeve
R	Round Spigot

Size Limitation		
Module	Size : Width x Height	Position
Single	Max X Max 30" x48"	V/H
Multiple	Max X Max 144" x 96"	V/H

Optional Construction (UL Certification N/A)

Frame : Stainless Steel 18 gauge (304/316L)

Blade : Stainless Steel 22 gauge (304/316L)

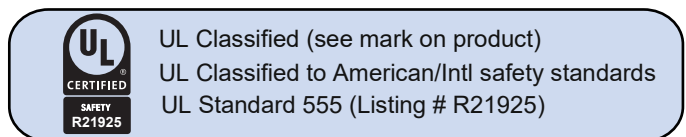

Selected Products of the company have been Classified / Listed / Tested by various international testing authorities.



UL-555 Classified Fire Damper

B-20/21/30/31 Series

Type : Fire Damper

Model : FD-GB-20/21/30/31

Construction : Galvanized Steel (GI)

UL / NFPA / SMACNA Recommended Installation Details

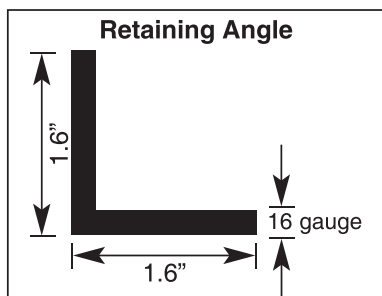
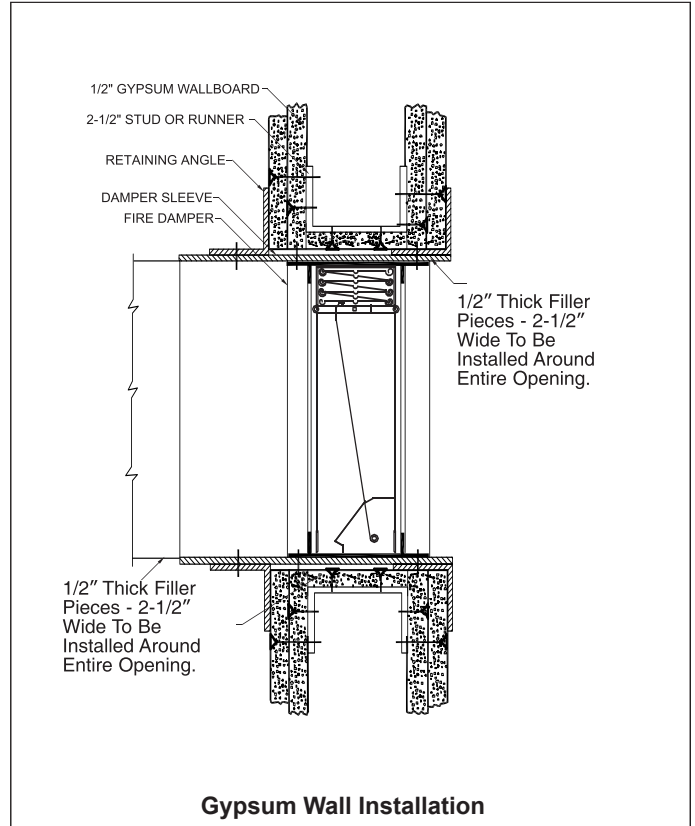
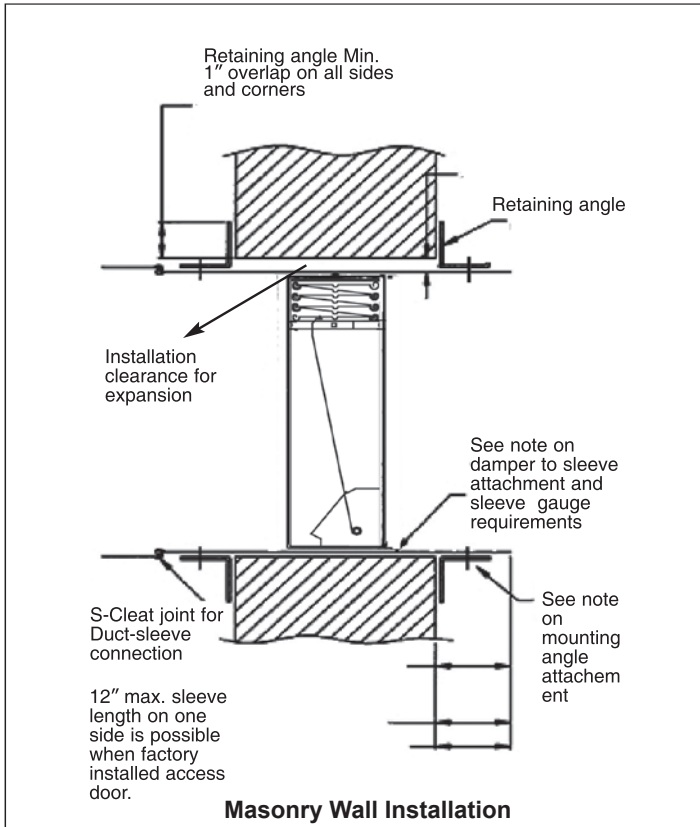

Notes:

1. Interruption of Duct Liner at the Fire Damper is required by NFPA Standard 90A. Where 90A is applicable, Installation should be made as shown and should otherwise conform to the SMACNA HVAC duct construction standards.

2. The designer should specify external insulation as shown to prevent condensation occurring on unlined metal at penetrations. where the provisions of NFPA 90A are applicable, neither insulation nor liner can extend through the walls or floors.

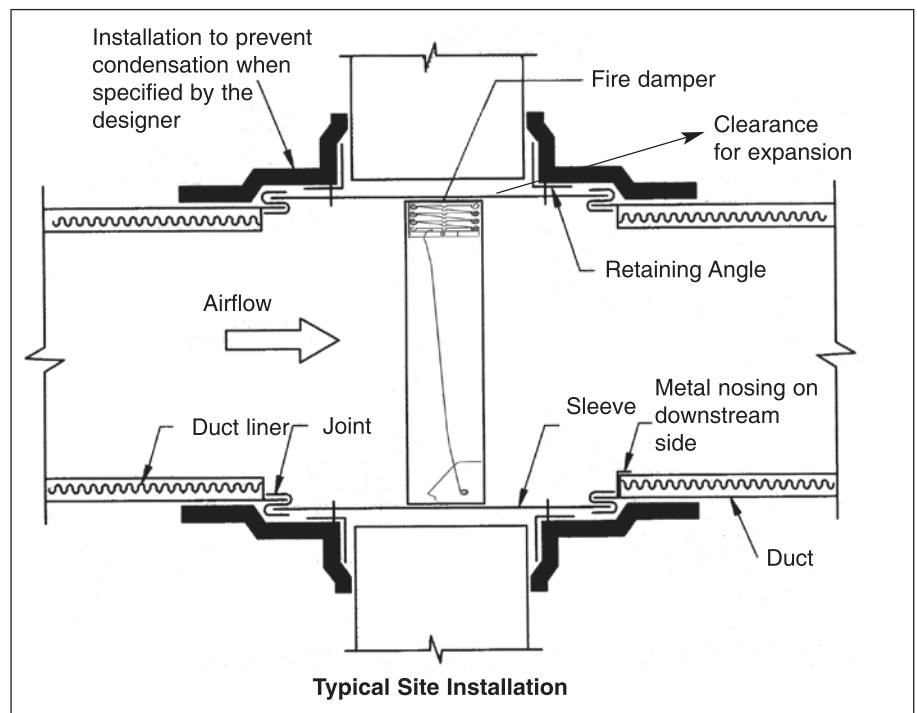

Selected Products of the company have been Classified / Listed / Tested by various international testing authorities.

UL-555 Classified Fire Damper

B-20/30/31 Series

Type : Fire Damper

Model : FD-GB-20/30/31

Construction : Galvanized Steel (GI)

UL / NFPA / SMACNA Recommended Installation Details

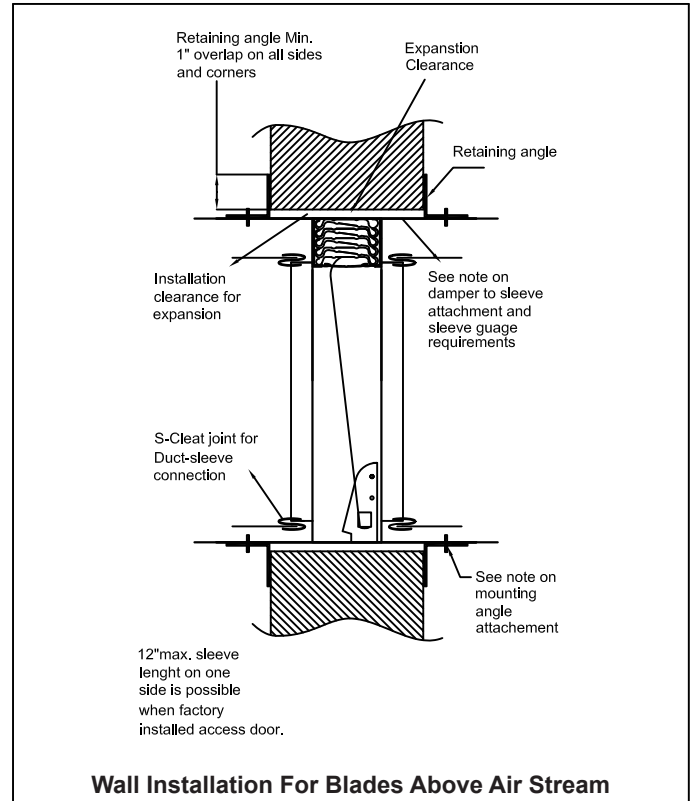
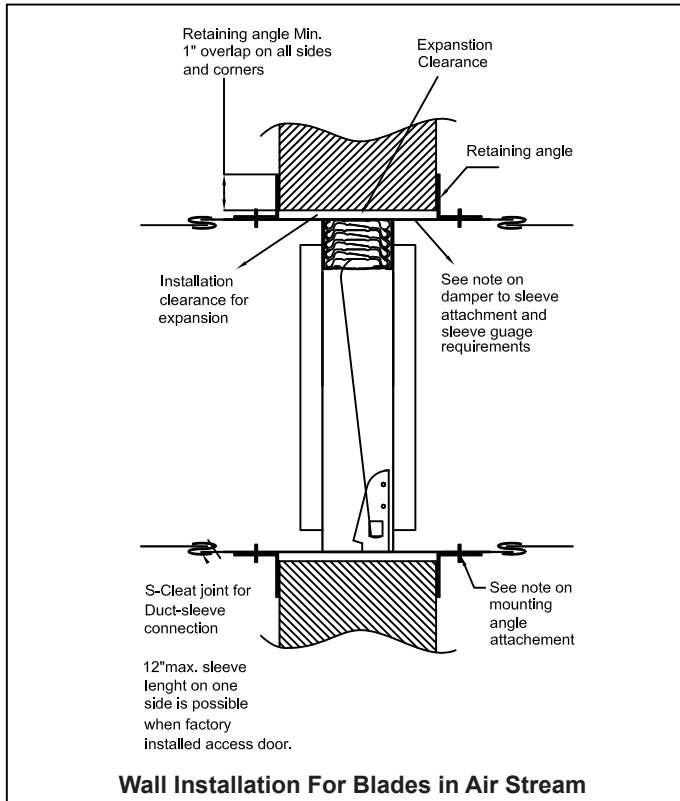

Recommended Minimum Sleeve Thickness for Fire Dampers. As per SMACNA - Table 5-2			
Type of Connection	Duct	Duct Dimension	Sleeve Gauge
Rigid	Round - Rectangular	24" (610 mm) maximum diameter 24" (610 mm) maximum height 36" (915 mm) maximum width	16 (1.613mm) Breakaway connection not required.
Rigid	Round - Rectangular	over 24" (610 mm) diameter over 24" (610 mm) height over 36" (915 mm) width	14 (1.994mm) Breakaway connection not required.
Breakaway	Round or Rectangular	12" (305 mm) and lower 13-30" (330- 760 mm) 31-54" (785- 1370 mm) 55-84" (1400- 2130 mm) 85" (2160 mm) and higher	26 (0.55 mm) 24 (0.70 mm) 22 (0.85 mm) 20 (1.0 mm) 18 (1.2 mm)

By UL 555, all ducts are required to terminate at the fire damper sleeves or the damper frames. Sleeve thickness is contingent on the type of connection. All UL listed dampers also have maximum dimensions associated with the test rating. Contingent on sleeve thickness a rigid connection may be used in lieu of a breakaway connection. Sleeves may be omitted where dampers are designed to be in non-ducted air passages or where damper housing permits attachment of retaining angles to the housing. Attachment of retaining angles must not restrict operation of the fire damper. Certain UL approved designs do not require retaining angles.

Where the fire damper sleeve is exposed to the airstream, the metal sleeve will be of the same material as the duct system. A steel sleeve, of the type or finish specified by the system designer, will be used for fibrous glass ductwork and where the fire damper sleeve is not exposed to the airstream

Selected Products of the company have been Classified / Listed / Tested by various international testing authorities.



UL-555 Classified Fire Damper
B-20/30/31 Series
Type : Fire Damper
Model : FD-GB-20/30/31
Construction : Galvanized Steel (GI)
Alternate Installations - As per SMACNA (UL Tested)

Alternate Fire Damper Installation Without retaining angles

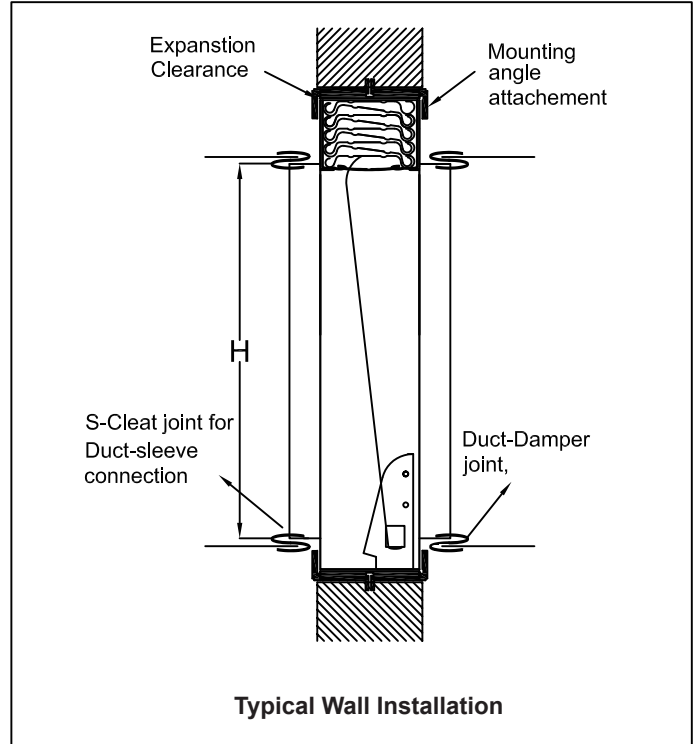
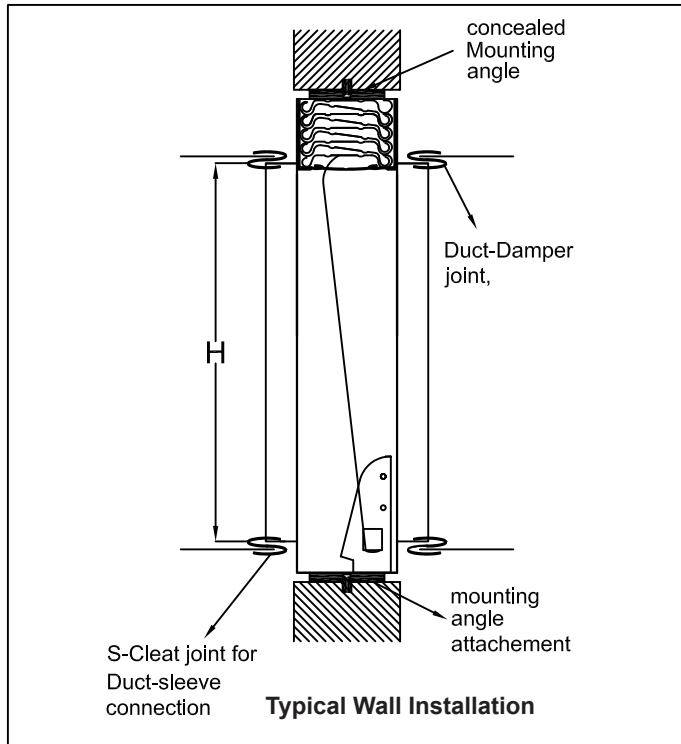
Grille Mounting Installation
Steel Grille

The steel grille (furnished by others) must include a minimum 12 gauge frame and blade. The grille must be fastened to angles provided with damper using no.10 sheet metal screws. Do not fasten grille directly to wall or floor. Grille shall overlap wall a minimum of 1/2" (12 mm).

Grille Mounting Angles

If grille mounting angles are furnished and installed in the field, they must be 2 mm x 2 mm x 12 gauge galvanized steel. They must be attached to the damper sleeve with a minimum of two 3/16" (4.8 mm) steel rivets per angle. The angles must be spaced as follows: Damper maximum size 36" x 36" (900 x 900), angles must be located on each vertical side of damper and centered at damper's height. Damper maximum size 36" x 36" (900 x 900) angles must be located on maximum 8" (200) spacing on vertical sides and 8" (200) on top and bottom.

Optional :

- 1) Mill finished.
- 2) Powder coated as per requirement.
- 3) Grille blades at 0° / 30° / 45° inclination.
- 4) Frame & blades thickness 3mm (8 gauge)

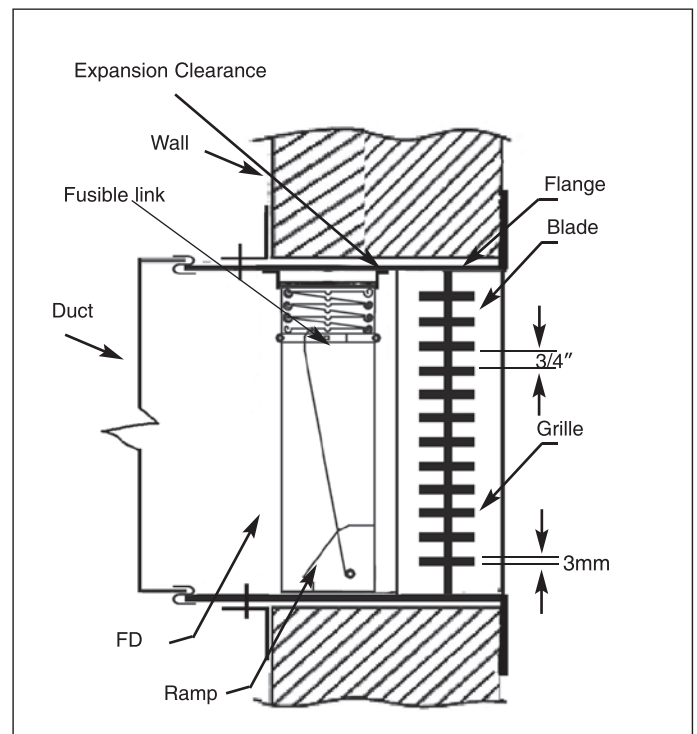

Selected Products of the company have been Classified / Listed / Tested by various international testing authorities.

UL-555 Classified Fire Damper

B-20/30/31 Series

Type : Fire Damper

Model : FD-GB-20/30/31

Construction : Galvanized Steel (GI)

Alternate Installations - As per SMACNA (UL Tested)

Optional Duct Sleeve connections by using Duct mate flanges.

Refer SMACNA figure 5-2 UL Duct Sleeve connections (Breakaway connections) recommended.

By using gaskets, metal cleats and four 3/8". (9.5mm) metal nuts and bolts

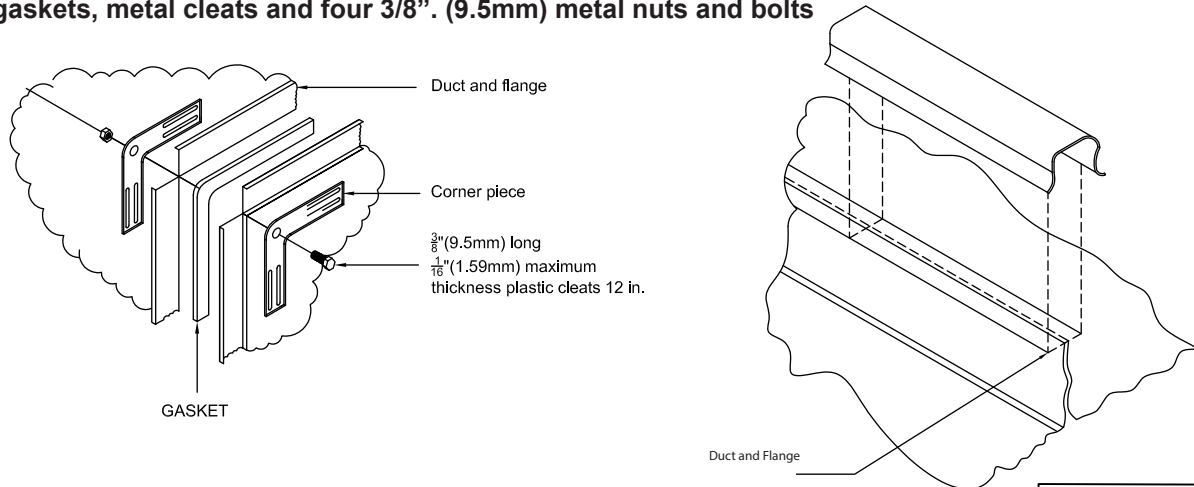

UL recommended Duct Sleeve connections or breakaway connections. by using gaskets and plastic cleats as shown below

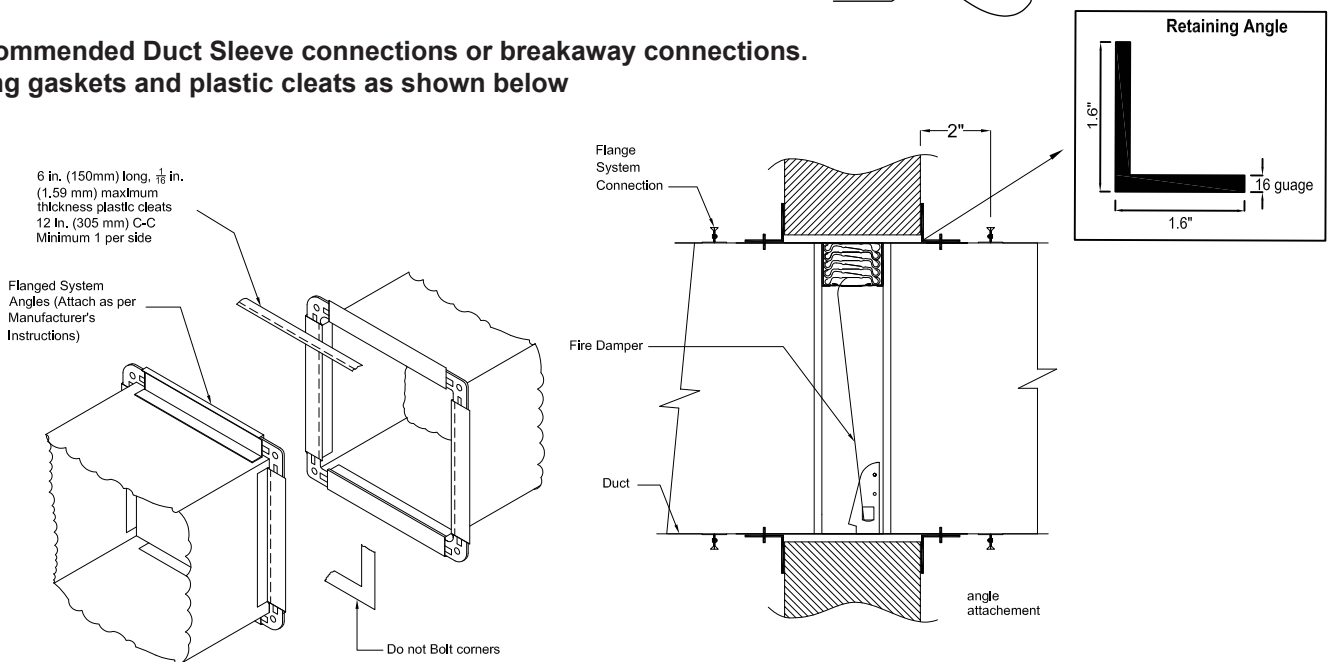

As per Smacna Figure 5-2 Page 5.6

Note 1 : 1991 UL Tests are described in UL Reference file NC 1380 Dated November 11, 1991 (UL Tested Connections)

Damper, Sleeve, Duct Standards.

FD-B damper when mounted with a factory sleeve, the standard mounting locations provide enough space for the mounting of Damper and allow space for installation of retaining angles and duct connections.

All accessories like corners, duct mate Flanges, metal or plastic cleats, retaining angles, bolts and nuts are of contractor's scope.

For Damper to Sleeve, Sleeve to retaining angles, duct to sleeve connections and installations shall be as per NFPA / SMACNA / UL standards.

Selected Products of the company have been Classified / Listed / Tested by various international testing authorities.



UL-555 Classified Fire Damper

B-20/30/31 Series

UL / NFPA / SMACNA Recommended Installation Details

Expansion Clearance

Minimum 1/8" per linear foot (10 mm per linear meter) of damper — both dimensions.(1/4" (6 mm) minimum). Clearance requirements for damper sleeves within a wall / floor opening .

Sleeve to Damper Connection

1. Secure Damper to Sleeve on 6" centers (150mm) with 1/2" (12 mm) long welds, 1/4" (6 mm) bolts and nuts or No. 10 Sheet Metal Screws. Sleeve thickness must be equal to or thicker than the duct connected to it . Sleeve gauge requirements are listed in the SMACNA Fire and Smoke Radiation Damper installation guide for HVAC systems and in NFPA 90. Damper sleeve shall not extend more than 6" beyond the fire wall or partition unless damper is equipped with an actuator and / or a factory installed access door. Sleeve may extend up to 16" beyond the fire wall or partition on sides equipped with actuator and or factory installed access door.

Retaining Angles

Retaining angles shall be a minimum of 1-1/2" x 1-1/2" x 16 ga (40x40x1.6mm). Retaining angles must overlap structure opening 1 inch minimum and cover corners of openings. For one angle installations the sleeve fasteners shall be placed at 6" (152) o.c and the wall fasteners shall be placed at 12" (305) o.c . For two angle installations the fasteners shall be spaced at 8" (203) o.c. Secure retaining angle to sleeve on <= 8" (203) with 1/2" (12 mm) long welds, 1/4" (6 mm) bolts and nuts or No. 10 Sheet Metal Screws

Mounting Details

Horizontally / vertically mounting recommended in walls / slabs / gypsum / floors.

Operation

To ensure optimum operation and performance , the damper must be installed so it is square and free from racking.Each fire smoke damper should be properly maintained , cycled and tested not less than every 6 months in accordance with NFPA 90 A, 92 A, UL 864.

Duct sleeve Connections

Duct - sleeve joints (UL - Recommended)

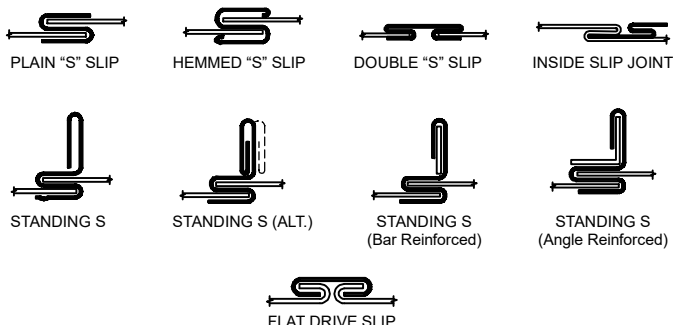

Round and Oval Break-away Connections

Round and oval spiral ducts attach to round or oval collars which are part of the damper sleeve as shown below. # 10 sheet metal screws are spaced equally around the circumference of the duct as per the following duct diameters 22" (560 mm) and smaller — 3 screws and duct diameters over 22" (560 mm) to and including 36" (915 mm) — 5 screws

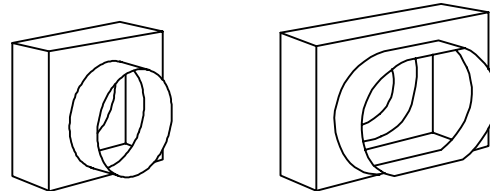

Flanged Break-away Style Duct/Sleeve Connections

TDC and TDF roll-formed flanged connections using 3/8" (9.5 mm) steel bolts and nuts, and metal cleats, as tested by SMACNA, are approved break-away connections when installed as shown on the Flanged System Breakaway Connections Supplement.

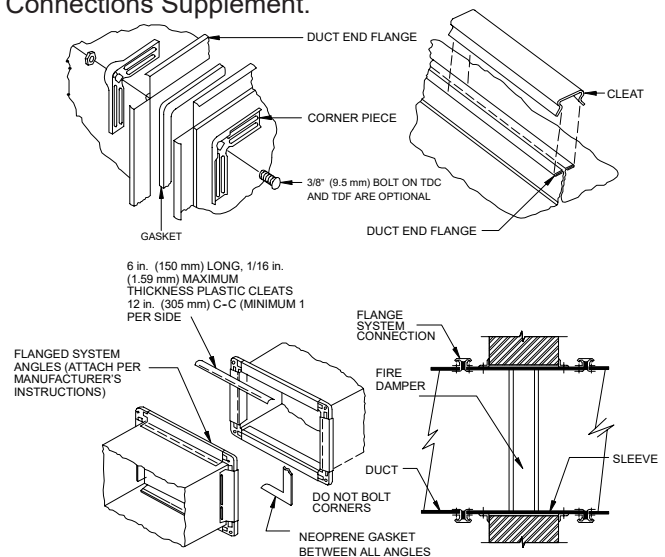

(UL TESTED CONNECTIONS)

Non-Break-away Duct/Sleeve Connections

If other duct/sleeve connections are used, the sleeve shall be a minimum of 16 gage (1.6) for dampers up to 36" (914) wide x 24" (610) high and 14 gage

Type of Connection	Duct	Duct Daimensions	Sleeve Gauge
Rigid	Round - Rectangular	24" (610 mm) Max Daimeter 24" (610 mm) Max Height and 36" (915 mm) Max Width	16+ (1.613 + mm)
Rigid	Round - Rectangular	over 24" (610 mm) Max Daimeter over 24" (610 mm) Max Height and over 36" (915 mm) Max Width	14+ (1.994 + mm)
Breakeaway	Round - Rectangular	12" (305 mm) and down 13-30" (330-760 mm) 31-54" (785-1370 mm) 55-84" (1400-2130mm) 85" (2160 mm) and up	26(0.55 mm) 24 (0.7 mm) 22 (0.85mm) 20 (1 mm) 18 (1.3mm)

+ Breakaway connections not required

Selected Products of the company have been Classified / Listed / Tested by various international testing authorities.

UL-555 Classified Fire Damper

B-20/30/31 Series

Type : Fire Damper

Model : FD-GB-20/30/31

Construction : Galvanized Steel (GI)

Optional Construction of Fire Damper

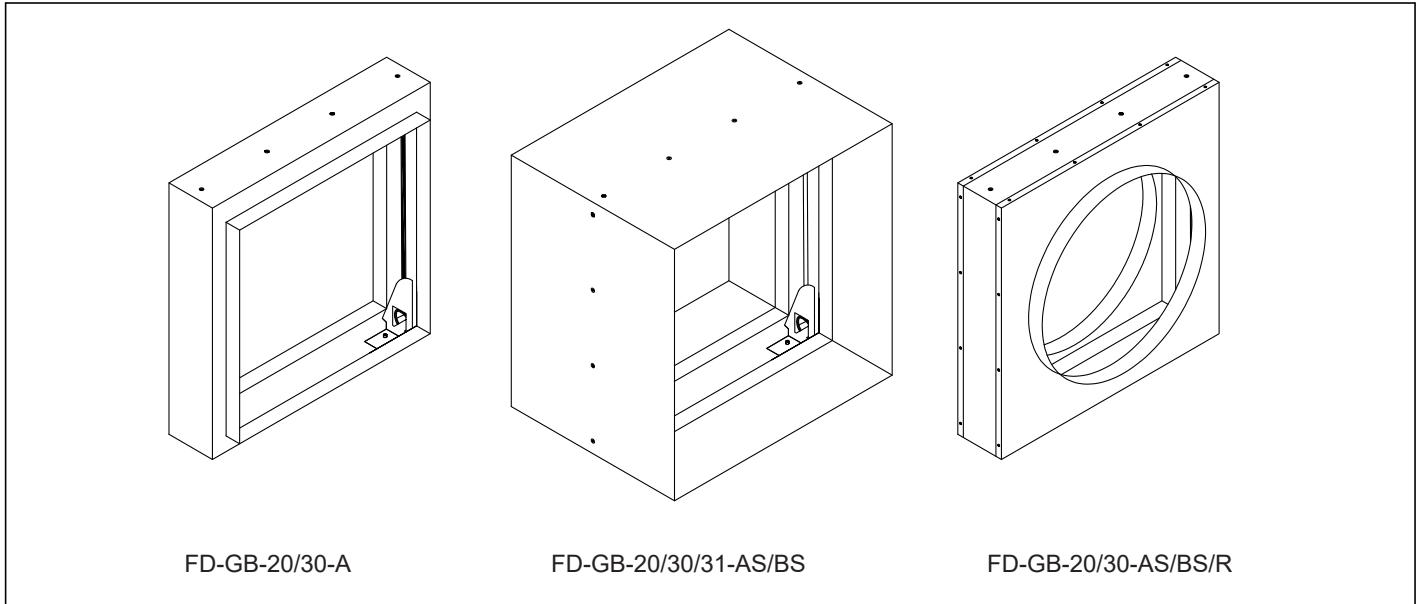

Multiple Module construction
Fire Dampers – Curtain Blade FD-GB-20 / FD-GB-30
Galvanized steel construction

Dampers larger than maximum single size are supplied as a factory assembly of two or more sections. The below figures show maximum damper sections size and assembly configurations for multi section dampers.

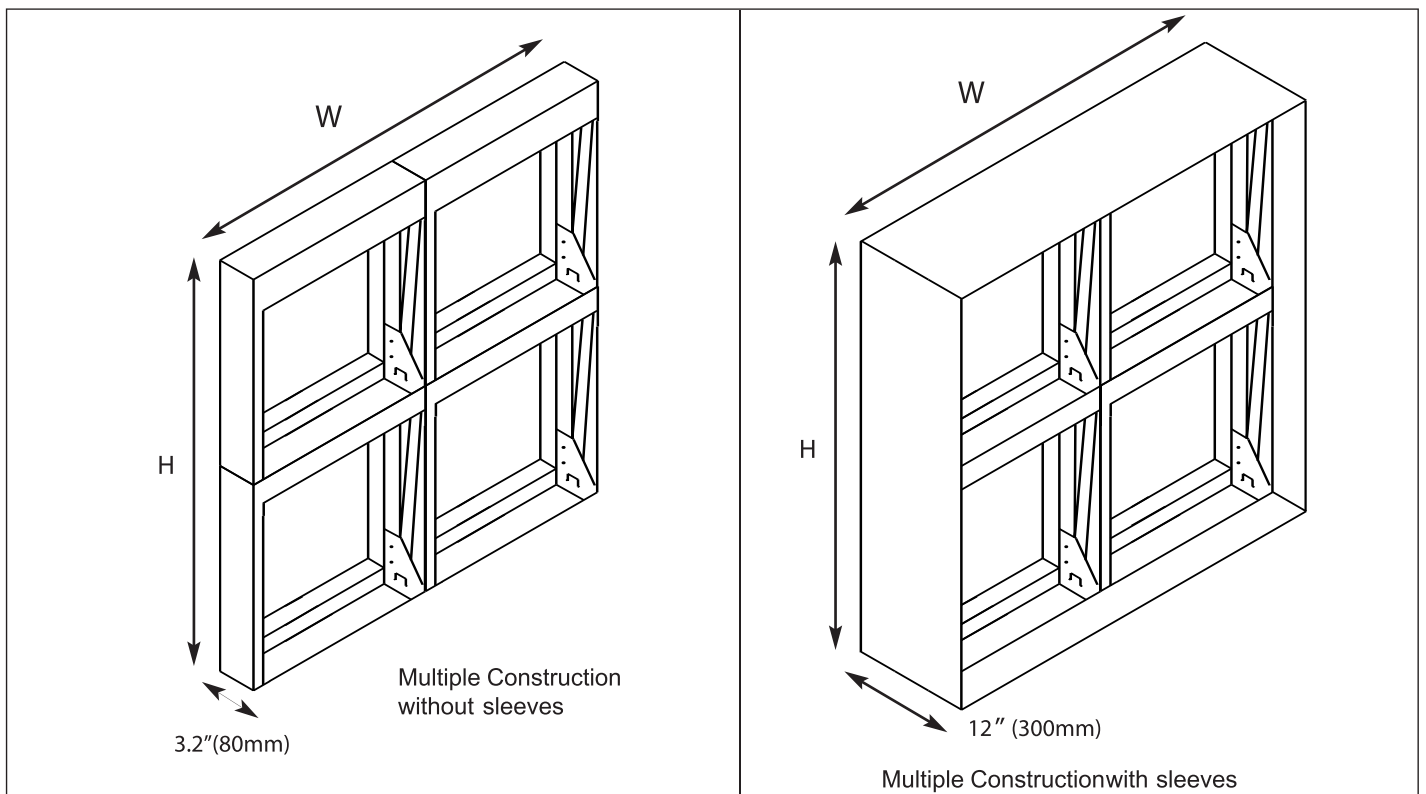

Selected Products of the company have been Classified / Listed / Tested by various international testing authorities.

UL-555 Classified Fire Damper

Type : Fire Damper

Model : FD-GB-20/30/31

Construction : Galvanized Steel (GI)

Optional Fitting for Fire Damper

Model: FD-GB-20/21/30/31 (UI Listed Limit Switch Option)

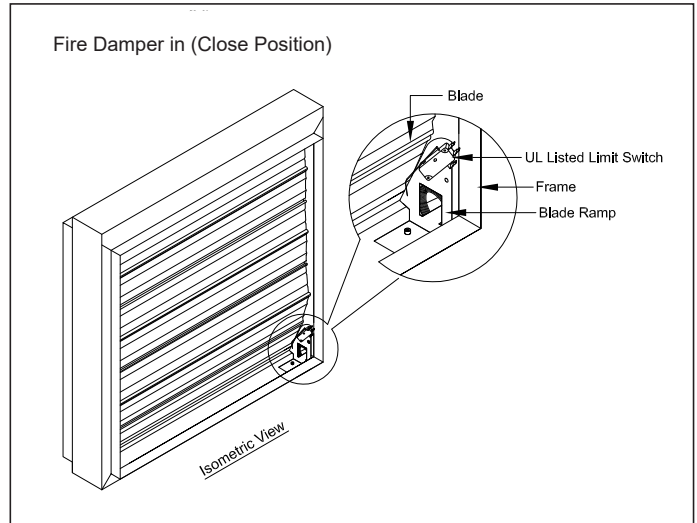
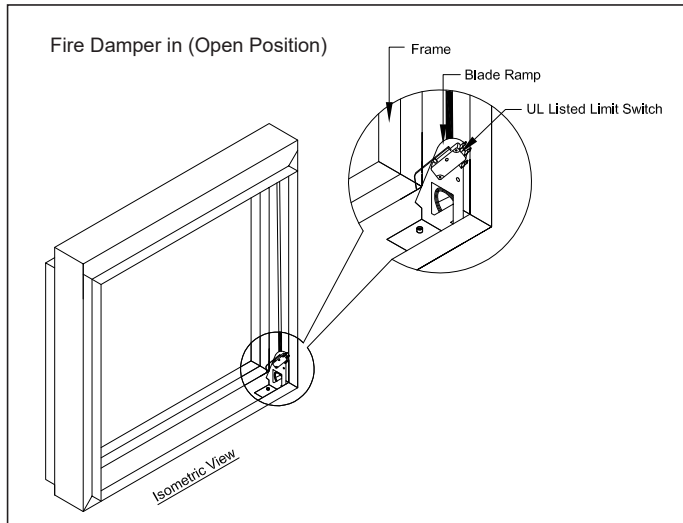

Technical Performance Data for Fire Damper

Model : FD-GB-20/21/30/31

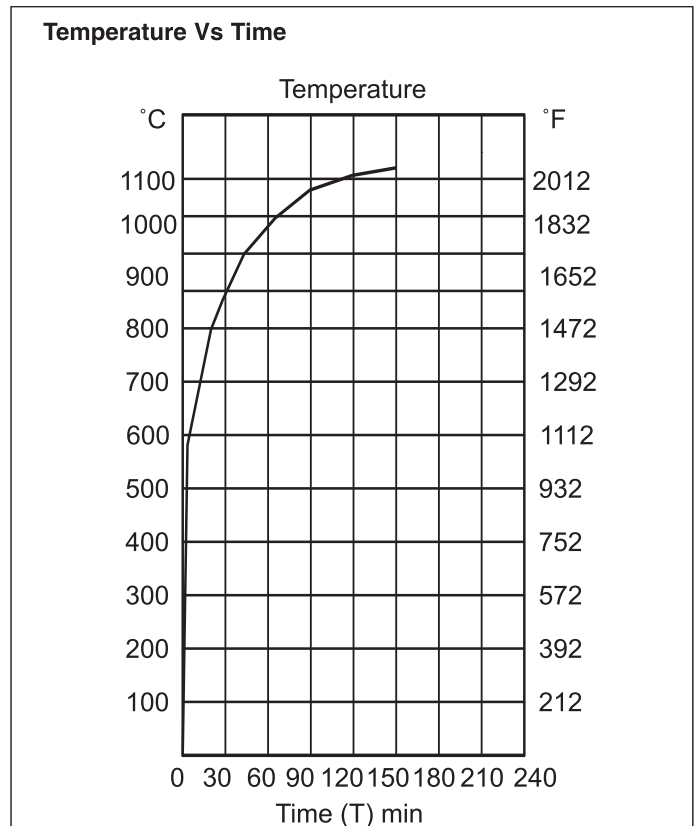
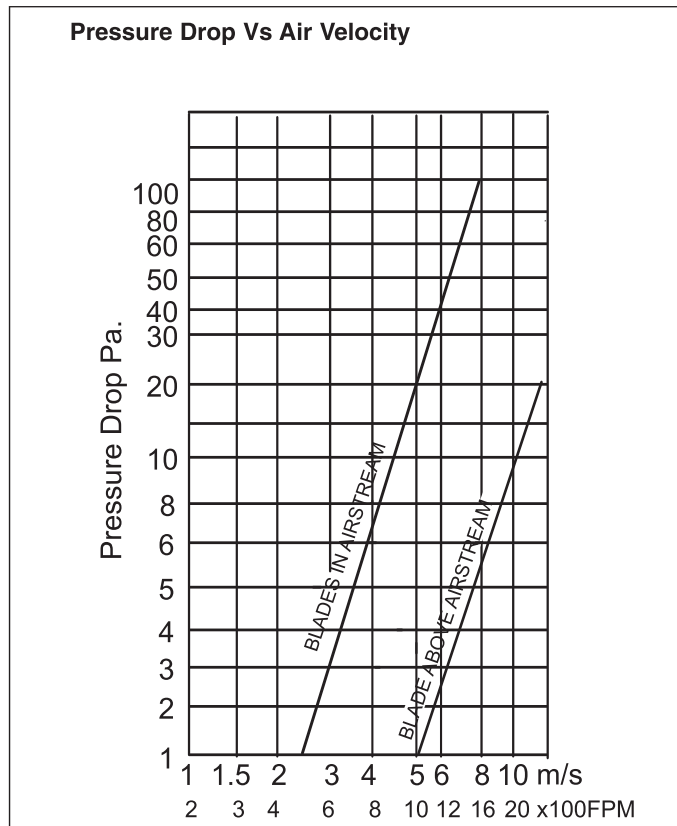

Selected Products of the company have been Classified / Listed / Tested by various international testing authorities.

UL-555 Classified Fire Damper**B-20/30/31 Series**

Type : Fire Damper
Model : FD-GB-20/30/31
UL 555 Fire Damper Tests.

Fire Endurance Test and Hose Stream Test (UL 555)

Dampers are exposed to a standard test fire for a period of either 1 1/2 or 3 hours. This standard test fire is controlled to follow the time temperature curve illustrated. Immediately after conclusion of this fire test, the dampers are subjected to a high pressure hose stream test during which water, at a nozzle pressure of 30 psi (207 kPa) for 1 1/2 hour dampers and 45 psi (310 kPa) for 3 hour dampers, is applied to the dampers from a distance of 20 feet (6 meters). The hose stream test provides an extreme shock that ensures the dampers are structurally strong enough to withstand the rigorous of the severest fire conditions.

Operational Reliability Cycle Test (UL 555)

Fire Dampers intended for operation by gravity or spring force (not driven by an actuator) must be cycled open and closed 250 times. Fire Smoke Dampers that are driven by an electric or pneumatic actuator must be cycled open and closed (by their actuator) 20,000 times. In addition to the 20,000 full stroke cycles, if the Fire Damper is also intended for use as a volume control damper, it must be cycled open and closed (by its modulating actuator) 100,000 repositioning cycles. These operational cycling tests are accomplished prior to the temperature degradation and leakage tests (described below) and ensure that the damper will function reliably after repeated operations.

Salt Spray Exposure Test (UL 555)

A damper sample is exposed to salt spray in a test chamber for a period of 120 hours. After this exposure, the damper must close (and latch if a latch is provided). This test demonstrates a damper's ability to function after a more severe fouling than the damper is likely to experience during its intended application.

Dynamic Closure Test (UL 555)

Fire dampers for dynamic systems shall be subjected to the dynamic closure test. Under specified airflow and heat, fire dampers for dynamic systems shall completely close and latch automatically (when a latch is provided) without damage to the fire damper or its components.



(Courtesy UL- USA)

BETEC CAD . Fire Damper Horizontal Fire Test.

Selected Products of the company have been Classified / Listed / Tested by various international testing authorities.



UL-555 Classified Fire Damper

B-20/30/31 Series

Type : Fire Damper

Model : FD-GB-20/30/31

Storage / Warranty / Maintenance

Receiving and Handling / Storage

The dampers needs to be handed carefully while loading or unloading as per the upright arrow marks given on the unit in the right position. Care should be taken in lifting the product in all 4 corners and placing them on a raised floor level. Don't pull or push the product on the floor level. Store the product always dry in environment do not expose the product to the dust or humid environment. Do not store at temperatures in excess of 100°F. Never expose this product to temperatures exceeding 140oF (60°C). After receiving the dampers, check for both obvious and hidden damages. If damage is found, record all necessary information on the bill of lading and file a claim with the final carrier. Check to be sure that all parts of the shipment, including accessories, are accounted for. Damper must be kept dry and clean. Indoor storage and protection from dirt, dust and the weather is highly recommended. For your safety and protection, follow all instructions and adhere to applicable building and electrical codes.

Safety Warning

Improper installation, adjustment, alteration, service or maintenance can cause property damage, injury or death. Read the installation, operating, and maintenance instructions thoroughly before installing or servicing this equipment.

Warranty

Betec cad warrants this equipment to be free from defects in material and workmanship for a period of one year from the purchase date. Any units or parts which prove to be defective during the warranty period will be required or replaced at our option. Betec cad shall not be liable for damages resulting from misapplication or misuse of its

products. Betec cad shall not be responsible for any installation or removal costs. Betec cad shall not be responsible for any service work done by a third party or back charges from the direct party.

Disclaimery

BETEC CAD's products are designed based on "SMACNA" and "NFPA" technological data in the interest of improving the safety for the public benefit. **BETEC CAD** disclaims any liability for any personal injury, loss of life, property damage, or other damage of any nature whatsoever, whether special, indirect, consequential or compensatory, direct or indirectly resulting from any accidents, regardless of legal theory. In no event shall **BETEC CAD's** liability exceed the amount paid by the customer / contractor to that individual product cost OR US\$1000/-which ever is lesser, regardless of legal theory

Damper Maintenance

Damper does not typically require maintenance as long as it is kept dry and clean. If cleaning is required, use mild detergents or solvents. If lubrication is desired for components such as axle bearings, jackshaft bearings and jamb seals do not use oil-based lubricants or any other lubricants that attract contaminants such as dust.

Once the installation is finished the contractor should note / record complete operation of the damper. Also, on the damper performance the Contractor / Building maintenance engineer should record the readings at every month intervals, the complete operation of the damper from full close and full open positions, date, time and maintenance engineer's name and signature.

Dampers and their actuator(s) must be maintained, cycled, and tested in accordance with:

The standards of UL555, NFPA 90A and SMACNA Actuator manufacturer recommendations

Fire Damper Troubleshooting

The following is a possible cause and correction list for common concerns with the dampers.

Symptom	Possible Cause	Correction
Damper does not fully open and / or close	Frame is 'racked' causing blades to bind on jamb seals	Adjust frame such that it is square and plumb
	Blade ramp loose	Close damper, adjust and tighten blade ramp
	Defective spring	Replace spring.
	Foriegn Screw in damper blades	Check Damper retaining angle screws installation..
	Contaminants on damper	Clean with a non-oil based solvent (see Damper Maintenance)
TRD sensor tripped (Fusible link)	TRD Heated	Replace TRD (see Damper Maintenance)

Selected Products of the company have been Classified / Listed / Tested by various international testing authorities.



Laboratory Tests and Certifications. (Tests Conducted at UL Head Quarters - Chicago, U.S.A)

UL 555 Laboratory Tests

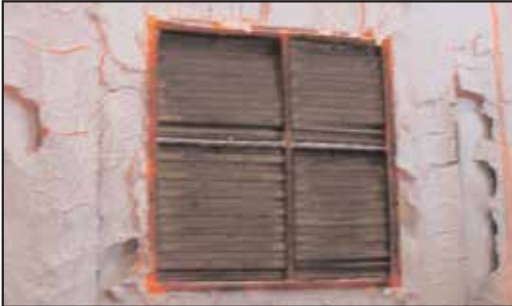
UL 555 Laboratory Tests Fire Damper After 2 hours - UL Laboratory

Fire Damper After 3 hours - UL Laboratory

Hose Stream Test - UL Laboratory

BETEC CAD's Tunnel Ventilation Damper 4 Hrs, Fire Resistance Tests
 Conducted by - BRE - UK Test Standard : BS476 Part 20-22

Damper Condition after 2 Hrs



Damper Condition after 4 Hrs

BS476 Part 20-22. (4 hrs Fire Test)

Selected Products of the company have been Classified / Listed / Tested by various international testing authorities.





beteccad.com



© Copyright reserved for *BETEC CAD*.

"Due to continuous progress and product improvement, *BETEC CAD* reserves the right to make changes without notice"

Sept - 2018