

Sand Trap Louver

B-40 Series

For Heavy duty applications

Model: STL-AB-41A; Blade Width: 1 – 100* mm; 2 – 130 mm

Type : A - Wall Mounted; B - Duct Mounted; C - Flush Mounted

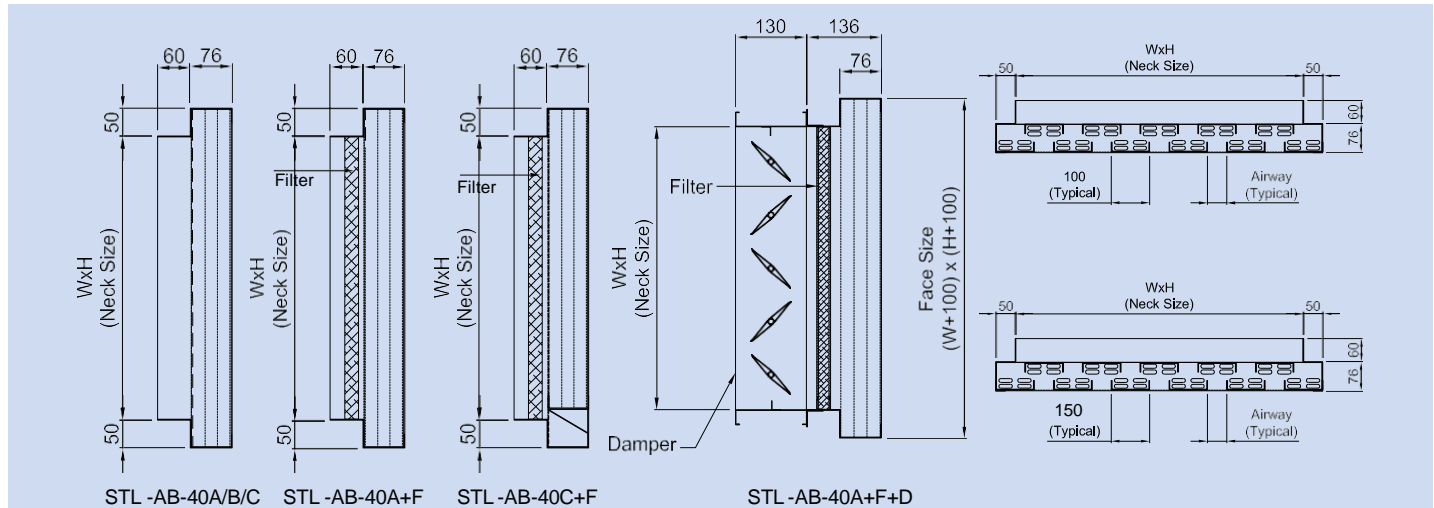

Standard Construction

Frame

2 mm thick extruded aluminum profile.

Blade

2 mm thick extruded aluminum profile.

Blade Orientation

Vertical

Blade Type

U Shaped 100 mm

Screen

Galvanized Steel 0.4 mm thickness.

Finish

Mill finish.

Optional Fittings

Blade

U Shaped 130 mm

Screen

S-3 SS Bird Screen

S-10 SS Fly Screen

Filter

13 / 25 mm thickness aluminum media filter.

Damper

Control Damper

Mounting Angles

Mounting frame and angle flange.

Finish

Available with powder coating, please specify color.

B-40 Series Model Details

Model	Frame		Blade	
	Material	Thickness	Material	Thickness
STL-AB-41/42A/B/C	AL	2 mm	AL	2 mm
STL-GB-41/42A/B/C	GI	2 mm	GI	2 mm
STL-SB-41/42A/B/C	SS	2 mm	SS	2 mm

Alphabet indicates the type of installation

A - Wall Mounted

B - Duct Mounted

C - Flush Mounted

Optional Construction Details

Frame : Thickness up to 4 mm

Blade : Thickness up to 4 mm

Any Combination of W x H

STL-AB-41/42														
Win Inchs	4"	6"	8"	10"	12"	14"	16"	18"	20"	22"	24"	26"	28"	30"
Hinches	4"	6"	8"	10"	12"	14"	16"	18"	20"	22"	24"	26"	28"	30"

Note:

Maximum single module construction - 3 x 2.5 meters

Multiple module available with mullion.

Applications :

- Sand Trap Louvers B-41 and B-42 Heavy duty model construction, are suitable for the duct or wall mounting applications in **HVAC** systems, where excessive intake air filtration is required for ventilation purpose.

Sand Trap Louvers fitted with filters and dampers are

- suitable for the **AHU's** applications for fresh air intake.

Note : Please contact **BETEC CAD.** for customized design and specification.

Selected Products of the company have been Classified / Listed / Tested by various international testing authorities.



Sand Trap Louver - STL

B-40 Series

Engineering and Performance Data

Selection table for **Model : STL-AB-40**

Free area Ak in mt ² For Model: STL-AB-40								
W/H	300	450	600	750	900	1050	1200	1500
300	0.007	0.014	0.021	0.029	0.036	0.043	0.050	0.065
450	0.014	0.029	0.043	0.058	0.072	0.087	0.101	0.130
600	0.021	0.043	0.065	0.087	0.108	0.130	0.152	0.195
750	0.029	0.058	0.087	0.116	0.145	0.174	0.203	0.261
900	0.036	0.072	0.108	0.145	0.181	0.217	0.253	0.326
1050	0.043	0.087	0.130	0.174	0.217	0.261	0.304	0.391
1200	0.050	0.101	0.152	0.203	0.253	0.304	0.355	0.456
1500	0.065	0.130	0.195	0.261	0.326	0.391	0.456	0.587

Model : STL-AB-40 Pressure Drop V/S Face Velocity Graph.

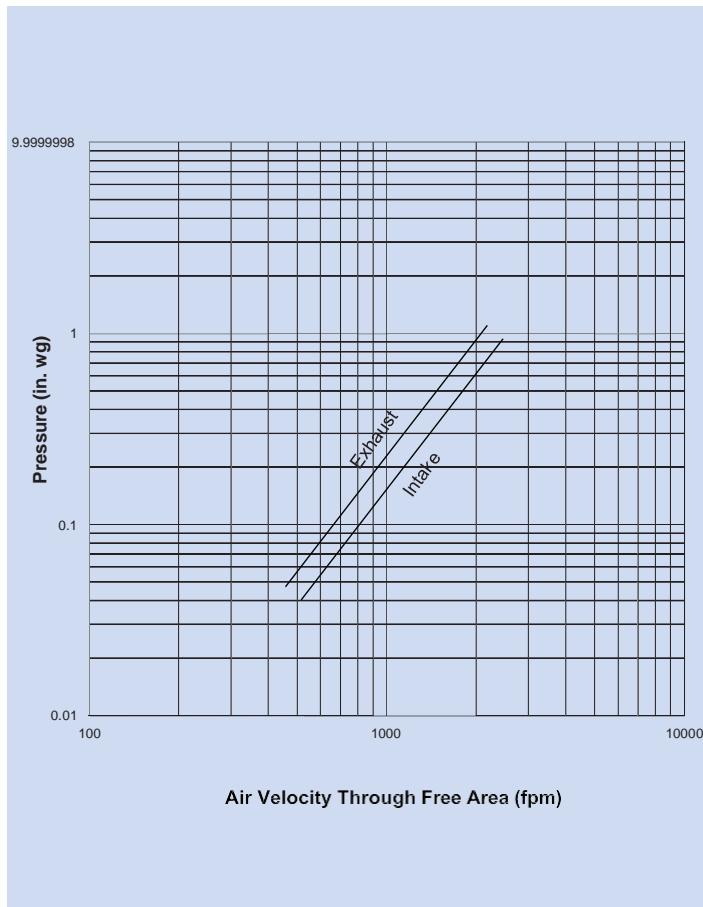

Model : STL-AB-40 Sand Rejection V/S Face Velocity Graph.

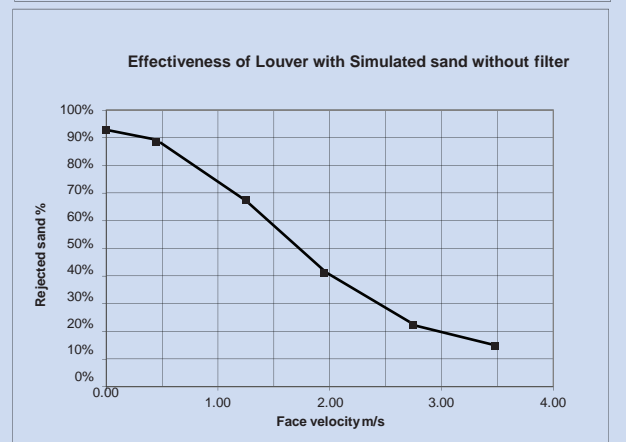
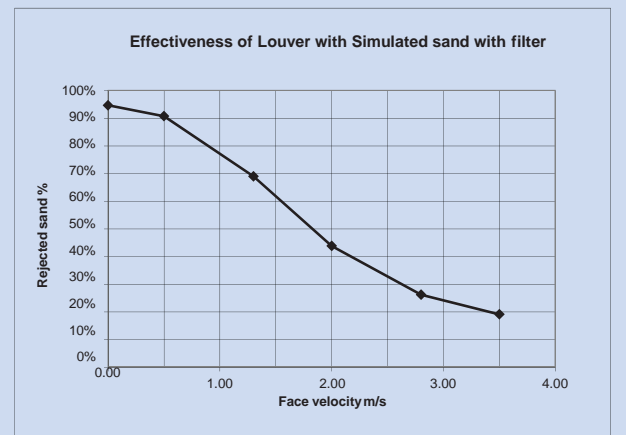

Sand Rejection Efficiency Model : STL-AB-40						
Description	STL		STL + F1		STL+F1+D+F2+F3	
	0.5 mt /s	1.0 mt /s	0.5 mt /s	1.0 mt /s	0.5 mt /s	1.0 mt /s
Face Velocity	0.5 mt /s	1.0 mt /s	0.5 mt /s	1.0 mt /s	0.5 mt /s	1.0 mt /s
Partical Size	150-700	150-700	75-150	75-150	75-150	75-150
% Efficiency	92%	75%	95%	77%	98%	96%

Selected Products of the company have been Classified / Listed / Tested by various international testing authorities.



Installation Details

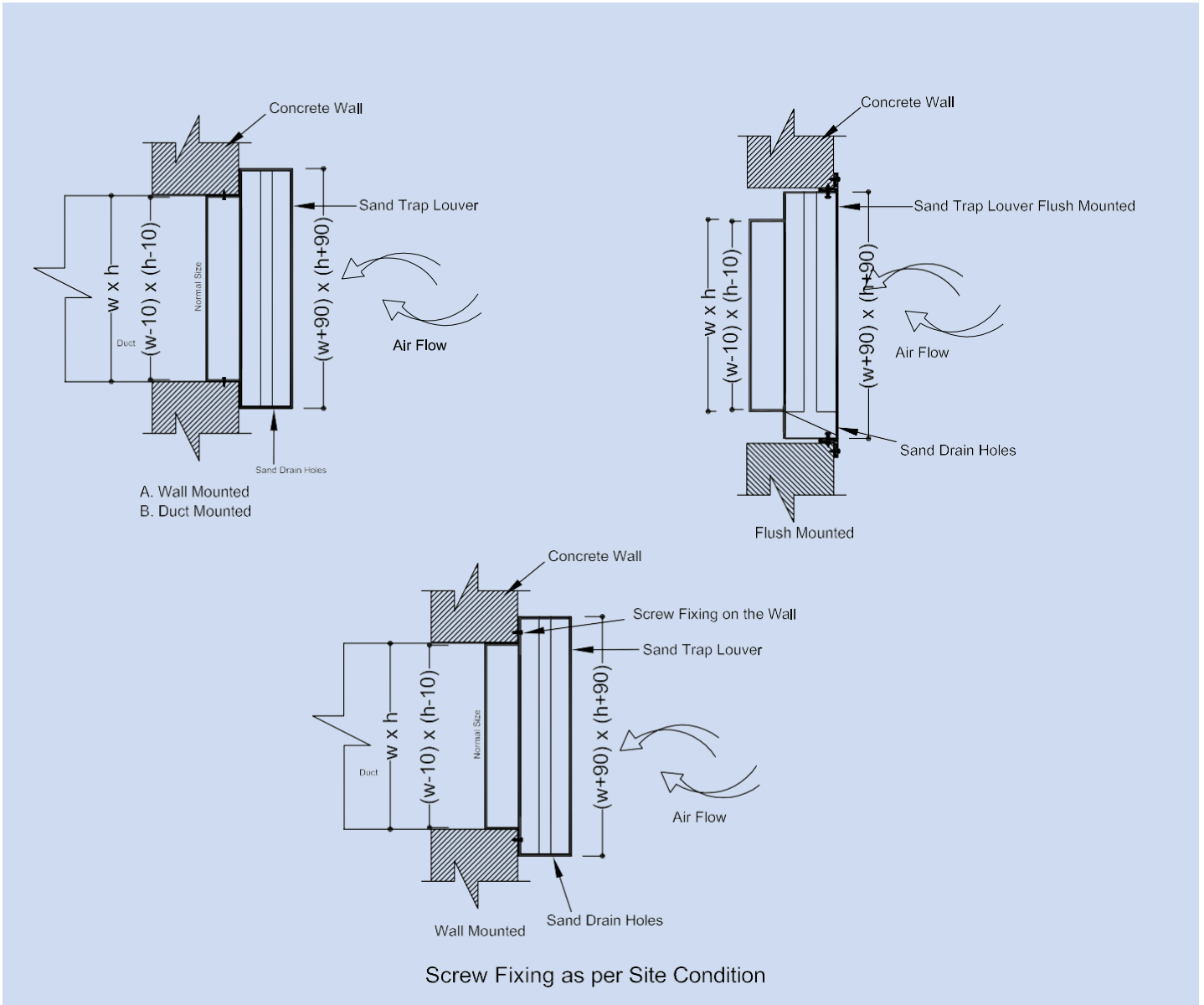

Note :

Fixing Details - Standard supply type screw fixing
 Recommended for side wall applications.

Selected Products of the company have been Classified / Listed / Tested by various international testing authorities.