

Linear Bar Grille

B - 20 Series

Type: Return Linear Bar Grille

Model : RLBG-AB-21

Deflection : Single

Throw: 15°, 2-way

Construction: Aluminium



Description

BETEC CAD.s B-20 Series Linear Bar Grilles are engineered to return air in heating, cooling and ventilating applications and are used for sidewall, floor, sill, and ceiling installations.

Frame and face bars are of high quality extruded aluminium profile, having 15°- 2 way throw .

The face bars are permanently fixed to the frame with 8- mm pipes and total structure is rigidly fixed to opposed blade damper by grippers to maintain straight-line appearance.This ensures positive control over the air stream. Damper blades can be screw operated from the face opening.

Standard Construction

Frame

Extruded aluminium profiles with 30 mm Flange width.

Face bars

Extruded Aluminium Solid blades at 15°, 2-way throw.

Bar Spacing

Standard Blade Spacing of 9 mm.

Finish

Available with RAL powder coating, please specify color.

Optional Construction

Flange

25 mm Flange width.

Foam Gasket

Provided all around the frame, to prevent leakage of air.

Damper

Opposed Blade Damper with extruded aluminium frame and blade operated with screw.

Damper Finish

Black matte.

Finish

Mill finish or Chrome plating.

Frame and Blades

Available in Stainless steel (304/316L).

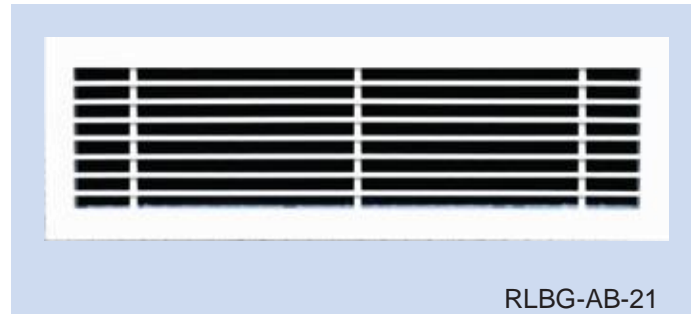

RLBG-AB-21

RLBG-AB-21 - Single Deflection Blade 15°

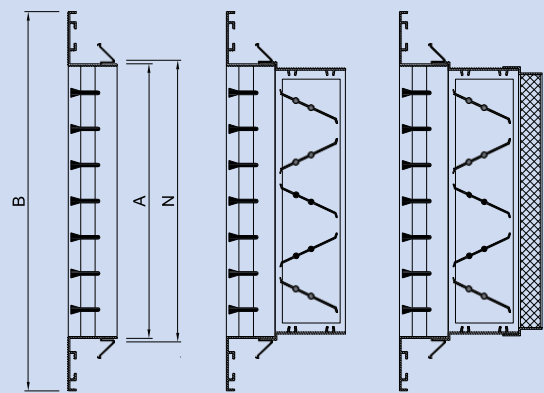

RLBG-AB-21

RLBG-AB-21-D

RLBG-AB-21-DF

Note:

N = Nominal Duct Size, **A** = Neck Size,
B = Overall Size (Face size), **D** = Damper ; **F** = Filter

Available Standard Sizes

Width of the Grille 'W'	Length of the Grille in Number of Pieces 'L'		
	1 Pc	2 Pcs	3 Pcs
50 mm	< 2 Mtrs	< 4 Mtrs	< 6 Mtrs
100 mm	< 2 Mtrs	< 4 Mtrs	< 6 Mtrs
150 mm	< 2 Mtrs	< 4 Mtrs	< 6 Mtrs
200 mm	< 2 Mtrs.	< 4 Mtrs	< 6 Mtrs
250 mm	< 2 Mtrs	< 4 Mtrs	< 6 Mtrs
300 mm	< 2 Mtrs	< 4 Mtrs	< 6 Mtrs
350 mm	< 2 Mtrs	< 4 Mtrs	< 6 Mtrs

Selected Products of the company have been Classified / Listed / Tested by various international testing authorities.

Linear Bar Grille Engineering and Performance Data.

B - 20 Series



Supply / Return Linear Bar Grilles

Width of the Grille (inches)	Area Factor (Ak)	Neck Velocity (FPM)	500	600	700	800	900	1000	1100	1200	1300	1400
2	0.038	CFM	201	243	285	327	369	411	453	495	537	579
		NC	<15	<15	17	20	22	26	30	33	36	39
		Throw	25,15,6	26,18,8	28,19,9	29,21,11	30,23,14	31,24,16	31,25,17	33,25,19	34,29,21	35,33,23
		Ps (in.w.g)	0.037	0.045	0.061	0.071	0.096	0.125	0.157	0.186	0.201	0.226
4	0.056	CFM	307	368	429	490	552	613	674	736	797	858
		NC	<15	17	22	26	30	34	37	39	42	44
		Throw	29,21,8	32,23,10	33,25,12	35,27,13	36,29,14	38,30,15	39,32,16	40,33,17	41,34,18	42,35,19
		Ps (in.w.g)	0.026	0.037	0.051	0.066	0.084	0.103	0.125	0.149	0.174	0.202
6	0.078	CFM	423	506	589	672	755	838	921	984	1067	1150
		NC	<15	17	19	20	22	24	26	27	29	32
		Throw	29,21,10	32,23,12	33,25,14	35,27,15	36,29,16	38,30,18	39,32,20	40,33,22	41,34,24	42,35,25
		Ps (in.w.g)	0.016	0.020	0.025	0.031	0.038	0.048	0.061	0.071	0.088	0.096
8	0.096	CFM	522	626	730	834	939	1043	1147	1252	1356	1460
		NC	<15	<15	16	21	25	29	33	36	39	42
		Throw	25,15,11	26,18,14	28,19,16	29,21,18	30,22,20	31,23,22	32,24,24	33,25,25	33,26,26	34,27,27
		Ps (in.w.g)	0.011	0.016	0.021	0.028	0.035	0.043	0.052	0.062	0.073	0.085
10	0.114	CFM	619	742	866	990	1113	1237	1361	1484	1608	1732
		NC	<15	<15	17	22	26	30	33	37	40	42
		Throw	25,15,12	26,18,15	28,20,18	29,22,20	30,23,22	31,24,24	32,25,26	33,26,27	33,27,28	34,29,29
		Ps (in.w.g)	0.008	0.011	0.015	0.020	0.025	0.031	0.038	0.045	0.053	0.061
14	0.148	CFM	800	960	1120	1280	1440	1600	1760	1920	2080	2240
		NC	15	20	25	29	33	36	39	42	44	47
		Throw	29,21,14	31,25,17	33,28,20	34,31,22	35,33,24	36,36,26	37,38,27	38,39,29	39,41,30	40,43,31
		Ps (in.w.g)	0.011	0.016	0.022	0.028	0.036	0.044	0.053	0.064	0.075	0.087

NC adjustment for various diffuser lengths, meters.

Length	0.5	1.0	1.5	2.0	3.0
NC	-3	0	+2	+3	+5

Note :

1. Airflow is measured in Cubic Foot/ minute (CFM).
2. Static Pressure (Ps) is measured in inch water guage (in.w.g).
3. Noise criteria (NC) is measured in decibals (dB).
4. Neck velocity is measured in feet/minute (fpm).
5. Throw is measured in feet (Ft).
6. Area factor (Ak) is measured in square meter (m²).

Selected Products of the company have been Classified / Listed / Tested by various international testing authorities.

